

# METAL SEPARATOR

## QUICKTRON 03 R

### DETECTION OF ALL TYPES OF METALS

- FERROUS
- STAINLESS STEEL
- ALUMINUM
- COPPER
- BRASS
- .....

RELIABLE DETECTION OF FREE OR ENCAPSULATED CONTAMINANTS.

Version 08/13



FRAME MOUNTED METAL SEPARATOR FOR THE INSPECTION OF GRAVITY FED BULK MATERIALS SUCH AS GRAIN, FEED GRANULATES, POWDERS, ...

### INDUSTRIES

- PLASTIC INDUSTRY
- RECYCLING INDUSTRY
- CHEMICAL INDUSTRY

### APPLICATION

- QUALITY CONTROL (TO MEET THE REQUIREMENT OF ISO 9000 AND HACCP).
- ASSURANCE OF METAL FREE GRANULATES AND PELLETS



## CONVINCING ARGUMENTS

- BUILT FOR THE PURPOSE.
- COMPACT DIMENSIONS AND DESIGN. ROUND PORTS ALLOW FOR A EASY AND TROUBLE FREE INTEGRATION INTO THE EXISTING PROCESS. QUICK AND EFFICIENT INSTALLATION.
- DESIGNED FOR ALL APPLICATIONS AND THROUGHPUTS. APERTURES FROM: 30-200 MM ( 1¼" TO 8.0" ) AVAILABLE.
- ANTI-STATIC SENSING TUBE – PREVENTS STATIC BUILDUP IN AND NEAR THE SENSING TUBE. FALSE REJECTS DUE TO STATIC DISCHARGE ARE AVOIDED.
- PRODUCT EFFECT COMPENSATION – GUARANTEES CONTINUOUS SENSITIVITY AND TROUBLE-FREE OPERATION EVEN WITH "DIFFICULT" PRODUCTS. "PRODUCT EFFECT" CANNOT CREATE FALSE REJECTS.
- SELF MONITORING – IN ADDITION TO THE DETECTION UNIT (COIL AND ELECTRONICS) THE OPERATING PRESSURE AND REJECT FUNCTION (OPTION) ARE PERMANENTLY MONITORED AS WELL. MALFUNCTIONS ARE INDICATED!
- THE DATA SHEET CONTAINS ADDITIONAL INFORMATION AS TO THE AMD 03 (VERSION 3.5) ELECTRONICS.

## WORKING PRINCIPLE

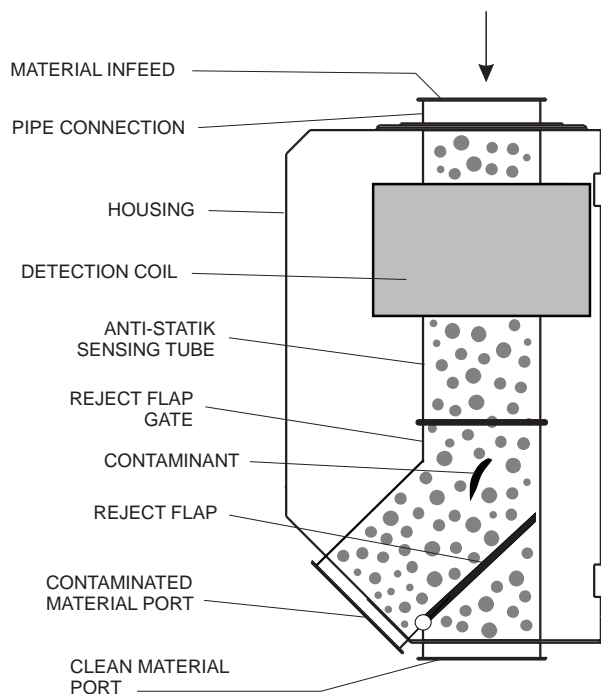

THE QUICKTRON SERIES ELECTRONIC METAL SEPARATORS AUTOMATICALLY DETECT AND REJECT METALLIC CONTAMINANTS FROM FREE FALLING BULK MATERIALS. CLEAN PRODUCT PASSES FREELY THRU THE REJECT ASSEMBLY. A CONTAMINANT IN THE PRODUCT STREAM ALTERS THE HIGH FREQUENCY FIELD GENERATED BY THE SEARCH COIL. THE ELECTRONICS EVALUATE THIS SIGNAL AND GENERATE AN IMPULSE FOR THE SOLENOID AND THE DOUBLE ACTUATING AIR CYLINDER OF THE REJECT ASSEMBLY. THE CONTAMINANT IS INSTANTLY DIVERTED FROM THE GOOD PRODUCT STREAM ASSURING MINIMAL GOOD PRODUCT LOSS. THE REJECT TIME IS ADJUSTABLE. IN THE CASE OF SEVERAL METAL PARTICLES BEING PRESENT, THE REJECT TIME WILL BE EXTENDED ACCORDINGLY, TO ASSURE A METAL FREE PRODUCT.

(ALL) METAL SEPARATOR QUICKTRON 03R



# DIMENSIONS

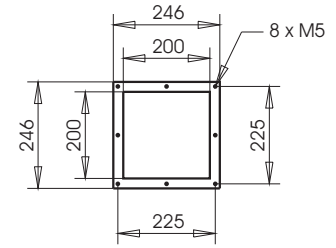
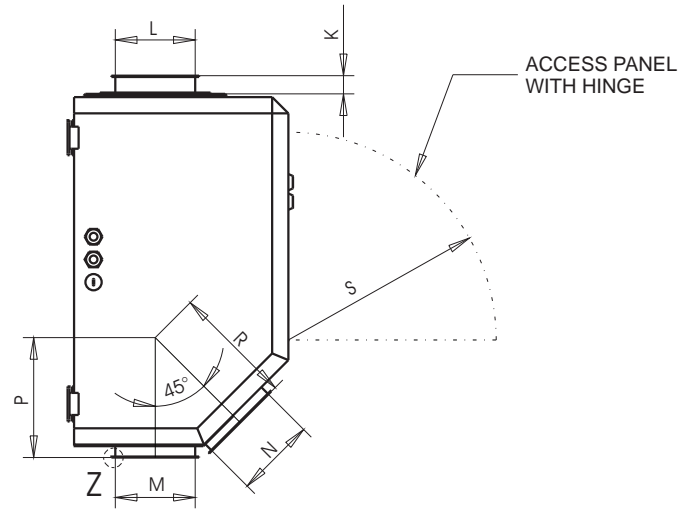
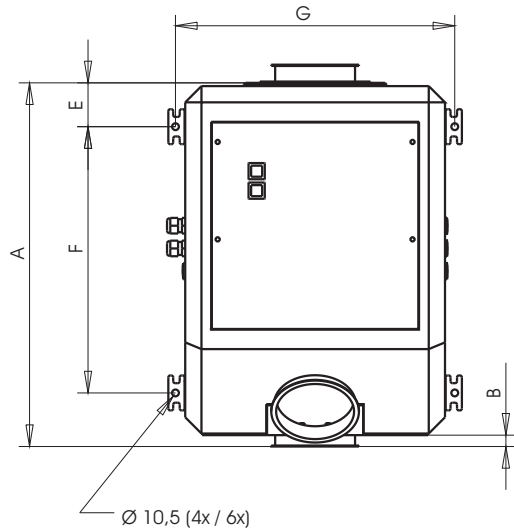

QUICKTRON QN 03 R - DN 200  
"GOOD" AND "REJECT" PORT

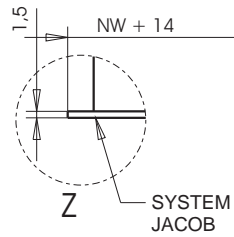
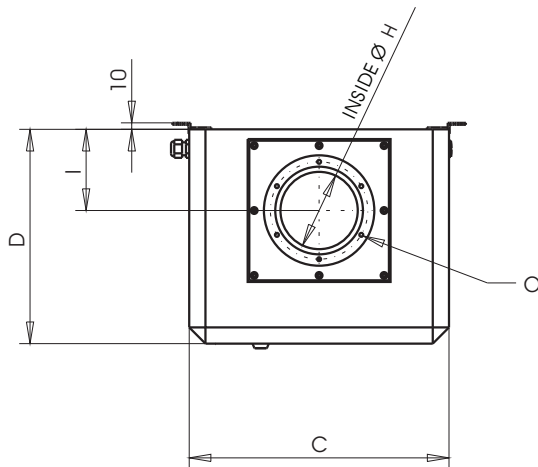

	DN 30	DN 50	DN 70	DN 80	DN 100	DN 120	DN 150	DN 200
<b>A</b>	420	420	420	577	577	560	650	700
<b>B</b>	18	18	18	35	35	18	17	---
<b>C</b>	300	300	300	400	400	400	450	500
<b>D</b>	250	250	250	330	330	330	380	460
<b>E</b>	60	60	60	67,5	67,5	67,5	77,5	81
<b>F</b>	290	290	290	410	410	410	240 / 480	270 / 540
<b>G</b>	330	330	330	430	430	430	480	530
<b>H</b>	Ø 32	Ø 45	Ø 70	Ø 80	Ø 98	Ø 111	Ø 142	Ø 177
<b>I</b>	95	95	95	125	125	125	160	165
<b>K</b>	---	---	---	35	28	28	36	37
<b>L</b>	---	---	---	NW Ø 80	NW Ø 100	NW Ø 120	NW Ø 150	NW Ø 200
<b>M</b>	NW Ø 80	NW Ø 80	NW Ø 80	NW Ø 80	NW Ø 100	NW Ø 120	NW Ø 150	□ 200
<b>N</b>	NW Ø 80	NW Ø 80	NW Ø 80	NW Ø 80	NW Ø 100	NW Ø 120	NW Ø 150	□ 200
<b>O</b>	4xM5/□72	4xM5/□72	4xM5/□130	6xM5/Ø108	6xM5/Ø130	6xM5/Ø150	6xM5/Ø180	6xM5/Ø230
<b>P</b>	134	134	134	202	202	185	230	276
<b>R</b>	135	135	135	202	202	185	230	301
<b>S</b>	275	275	275	320	320	320	300	300
<b>WEIGHT [kg]</b>	20	20	20	32	32	32	50	61

ALL DIMENSIONS IN MM.

OPTION

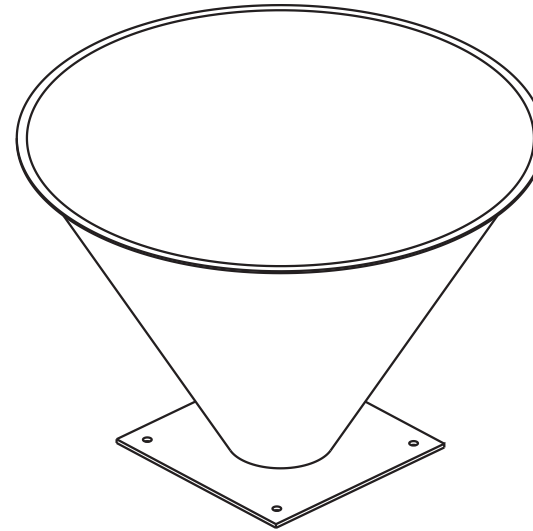
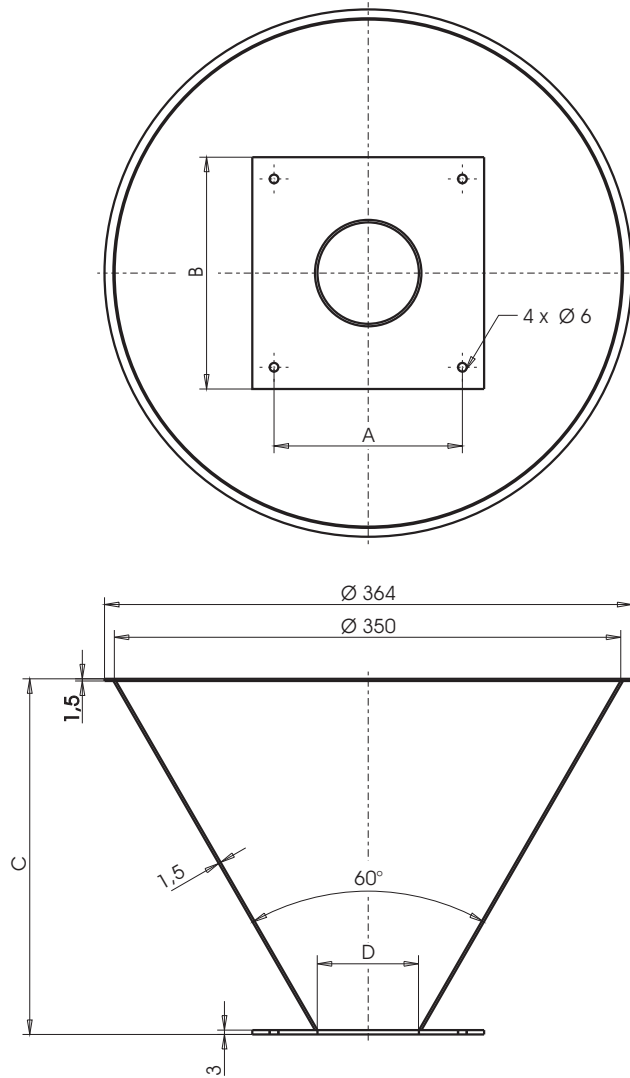

	TR 350-30	TR 350-50	TR 350-70
<b>A</b>	□ 72	□ 72	□ 130
<b>B</b>	□ 100	□ 100	□ 160
<b>C</b>	278	263	245
<b>D</b>	Ø 30	Ø 50	Ø 70

ALL DIMENSIONS IN MM.

## MATERIALS EMPLOYED

HOUSING:	ELO (DC 01 + ZE 25-25 APC), POWDER-COATED (RAL 3027)
COVER PLATE:	PP (POLYPROPYLENE)
SENSOR TUBE:	ELECTRICALLY CONDUCTIVE POLYETHYLENE (PE)
CONNECTING FLANGE:	STEEL, GALVANIZED
EJECT HOUSING:	DN 30 – DN 150 = PRESSURE CAST ALUMINUM DN 200 = STAINLESS STEEL (1.4301 / SUS 304)
EJECT FLAP:	DN 30 – DN 150 = STAINLESS STEEL (1.4301 / SUS 304) DN 200 = GFK (FIBERGLASS REINFORCED PLASTIC)
SHAFT:	DN 30 – DN 200 = STAINLESS STEEL (1.4301 / SUS 304)
SEALING MATERIALS:	PU (POLYURETHANE)

"GOOD" AND "REJECT" PORT TRANSITIONS INSTALLED ON UNITS WITH 200 MM PORTS MATERIAL: STAINLESS STEEL (1.4301 / SS 304)

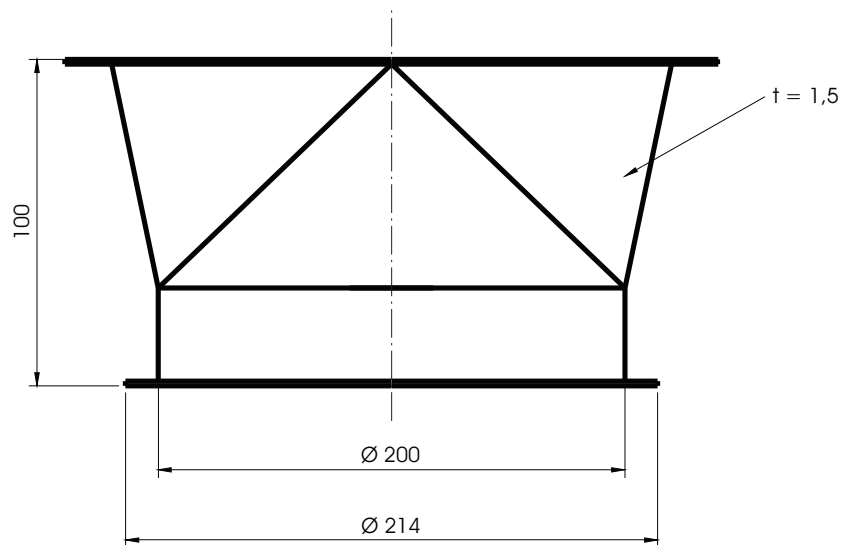

ALL DIMENSIONS IN MM.

WE OFFER PROJECT SPECIFIC TRANSITIONS FOR EVERY UNIT IN ALL SHAPES AND SIZES. PLEASE CONSULT THE SALES DEPARTMENT.

## INSTALLATION AND OPERATION INSTRUCTIONS

- THE METAL SEPARATOR NEEDS TO BE INSTALLED VERTICALLY.
- DO NOT EXCEED 0,5 M ( 18" ) MAXIMUM FREE FALL HEIGHT FROM TOP OF UNIT.
- PLEASE MAKE SURE THAT THERE IS ENOUGH SPACE UNDERNEATH THE METAL SEPARATOR. IF THE MATERIAL CANNOT EXIT FREELY IT WILL BLOCK THE REJECT FLAP AND PREVENTS THE REJECTION OF METAL CONTAMINANTS.
- INSTALL THE METAL SEPARATOR IN A VIBRATION FREE ENVIRONMENT. THE FRAME OF THE METAL SEPARATOR HAS 4 MOUNTING BRACKETS. THE OPPOSITE MOUNTING FLANGES HAVE TO BE ABLE TO SUPPORT THIS WEIGHT.
- DO NOT INSTALL MOVING METAL PARTS IN FRONT OF THE APERTURE. THE DISTANCE OF GATES, FLAPS AND OTHERS MUST BE AT LEAST 1x OF THE APERTURE WIDTH.
- DO NOT INSTALL THE METAL SEPARATOR NEAR STRONG ELECTROMAGNETIC INTERFERENCE FIELDS. POTENTIAL INTERFERENCE MAY BE CAUSED BY LARGE ELECTRIC MOTORS, HIGH VOLTAGE LINES, INSUFFICIENT SHIELDED FREQUENCY CONVERTERS AND SUCH.
- KEEP THE METALSEPARATOR UNDER POWER AT ALL TIMES. THE INITIALIZATION PERIOD AFTER POWER UP IS 15 SECONDS.
- POLL THE FAULT INDICATOR AT (CONNECTION BLOCK (C)).

## SENSITIVITY AND THROUGHPUT DIAGRAM

MODEL DN	30	50	70	80	100	120	150	200
SENSITIVITY <sup>1)</sup> STEEL BALL Ø MM	0,4	0,4	0,6	0,7	0,8	0,9	1,2	1,75
THROUGHPUT <sup>2)</sup> LITER / HOUR	3000	8500	17000	22000	34000	49000	77000	137000

<sup>1)</sup> THE SENSITIVITY IS PROPORTIONAL TO THE DIAMETER OF THE APERTURE. THE SMALLER THE APERTURE, THE HIGHER THE SENSITIVITY. THE ABOVE STATED VALUES WERE OBTAINED IN THE CENTRE OF THE APERTURE UNDER SIMULATED PRODUCTION CONDITIONS AND ARE VALID FOR MOST DRY POWDERS AND GRANULATES.

MAXIMUM OBTAINABLE SENSITIVITY VALUES CAN BE ESTABLISHED BY TESTING YOUR PRODUCT SAMPLE IN OUR LABORATORY.

SENSITIVITY VALUES FOR OTHER MATERIALS:  
STAINLESS STEEL: FE SPHERE x 1,0 UP TO 1,8 (DEPENDENT ON THE ALLOY)

NON-FERROUS MATERIALS SUCH AS BRONZE, COPPER, ALUMINUM: FE SPHERE x 1,0 UP TO 1,4 (DEPENDENT ON THE TYPE OF METAL).

<sup>2)</sup> THE ABOVE STATED VALUES ARE APPROXIMATE. ACTUAL VALUES DEPEND ON THE FLOWABILITY, BULK DENSITY AND METHOD OF INFEEED. PLEASE CONSULT OUR APPLICATIONS DEPARTMENT.

AS GROUND MATERIAL BRIDGES, THE APERTURE WIDTH OF DN 30 IS NOT SUITABLE FOR APPLICATIONS AFTER SIZE REDUCTION EQUIPMENT. EVEN WITH LARGER DIAMETERS, DO NOT USE MORE THAN 25% OF THE THROUGHPUT AS STATED IN THE TABLES TO AVOID BRIDGING.

## CONTROL UNIT AMD 03 (VERSION 3.5)

ADVANTAGES THAT WILL CONVINCEN YOU!

### AUTO BALANCING

DURING POWER UP AS WELL AS DURING STANDARD OPERATION, THE CONTROL UNIT CONTINUOUSLY BALANCES ITSELF. OVER TIME, COILS MAY SHIFT AND SENSITIVE COMPONENTS MAY LOOS TOLERANCE. TEMPERATURE ALSO HAS AN EFFECT ON THE PERFORMANCE AND MUST BE COMPENSATED FOR. THIS SELF BALANCING ROUTINE INSURES THAT THE DETECTOR IS CONTINUOUSLY OPERATING AT MAXIMUM PERFORMANCE.

### PRODUCT EFFECT COMPENSATION

ELECTRICALLY CONDUCTIVE OR HUMID PRODUCTS CAN CAUSE EXTREME LOSS OF SENSITIVITY OR EVEN RENDER CONVENTIONAL DETECTORS USELESS. THE EVALUATION ELECTRONIC SYSTEM AMD 03 ELIMINATES THESE PRODUCT EFFECTS ELECTRONICALLY AND GUARANTEES A CONSTANT SENSITIVITY.

### SERVICE FRIENDLY

EASY TO DIAGNOSE:  
OPTICAL FAULT INDICATION WITH LED'S  
"DO IT YOURSELF-REPAIRS" ARE EASY. "PLUG AND PLAY" CONNECTORS, A QUARTZ DRIVEN SENDER FREQUENCY AND THE SINGLE MOTHERBOARD CONSTRUCTION GUARANTEE EASE OF REPAIR. ALL AMD 03 MOTHERBOARDS ARE 100% COMPATIBLE!

### TEMPERATURE COMPENSATION

CUTTING EDGE TECHNOLOGY! EVEN EXTREME TEMPERATURE FLUCTUATIONS ARE EFFORTLESS COMPENSATED WITHOUT AFFECTING THE FUNCTIONS OF THE METAL SEPARATOR.

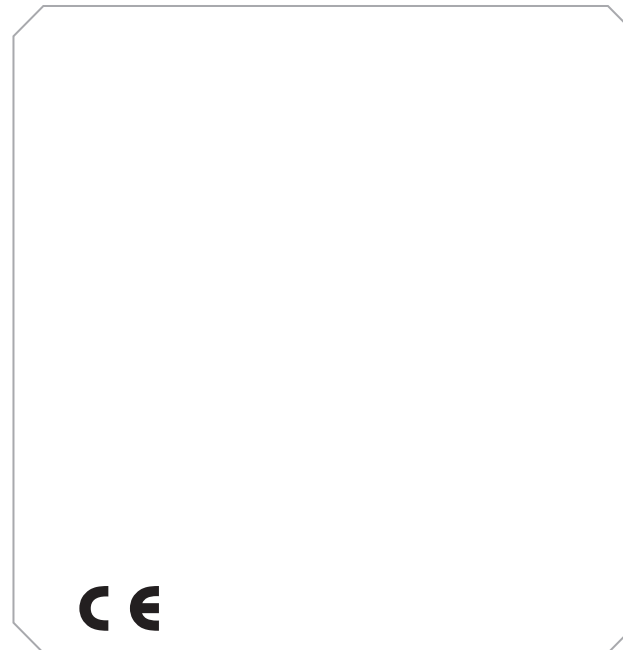

### EASY TO OPERATE

EASY TO USE CONTROLS ALONG WITH VISUAL DISPLAYS MAKE THE INSTALLATION AND OPERATION OF THE AMD 03 EFFORTLESS.

### NOISE SUPPRESSION

BY ADDING DYNAMIC DIGITAL FILTRATION CIRCUITRY, VIBRATIONS WHICH ARE OFTEN TRANSFERRED TO THE DETECTOR CAN NOW BE FILTERED OUT WITHOUT HAVING TO LOWER THE SENSITIVITY OF THE SYSTEM.

### SELF MONITORING FEATURES

THE SYSTEM IS FULLY AUTOMATIC AND CONTINUOUSLY MONITORED. MALFUNCTIONS ARE RELIABLY INDICATED. IN ADDITION FAULT S IN THE MAIN COMPONENTS ARE INDICATED THRU LED'S. THE REJECT FLAP REMAINS IN THE REJECT POSITION IN CASE OF A MALFUNCTION, LOSS OF POWER OR AIR PRESSURE (OPTION) UNTIL THE PROBLEM HAS BEEN ELIMINATED.

### QUALITY

4. 43 " .0/5 7 4 )7 / 4 /5)  
130 5 0/ 0 5) 0/530-4 5): /05 0/-: 0 3 "  
0.1" 5 4 (/ 5"-401307 ") () 3 2 "-5:"/  
.03 30 451 3 03."/ / 3)"34) 0/ 5 0/4 "--  
/5 /(130 54. 55) 3 2 3. /50 / 7 7  
77"/ 3 (-"5 0/4



## CONTROLS

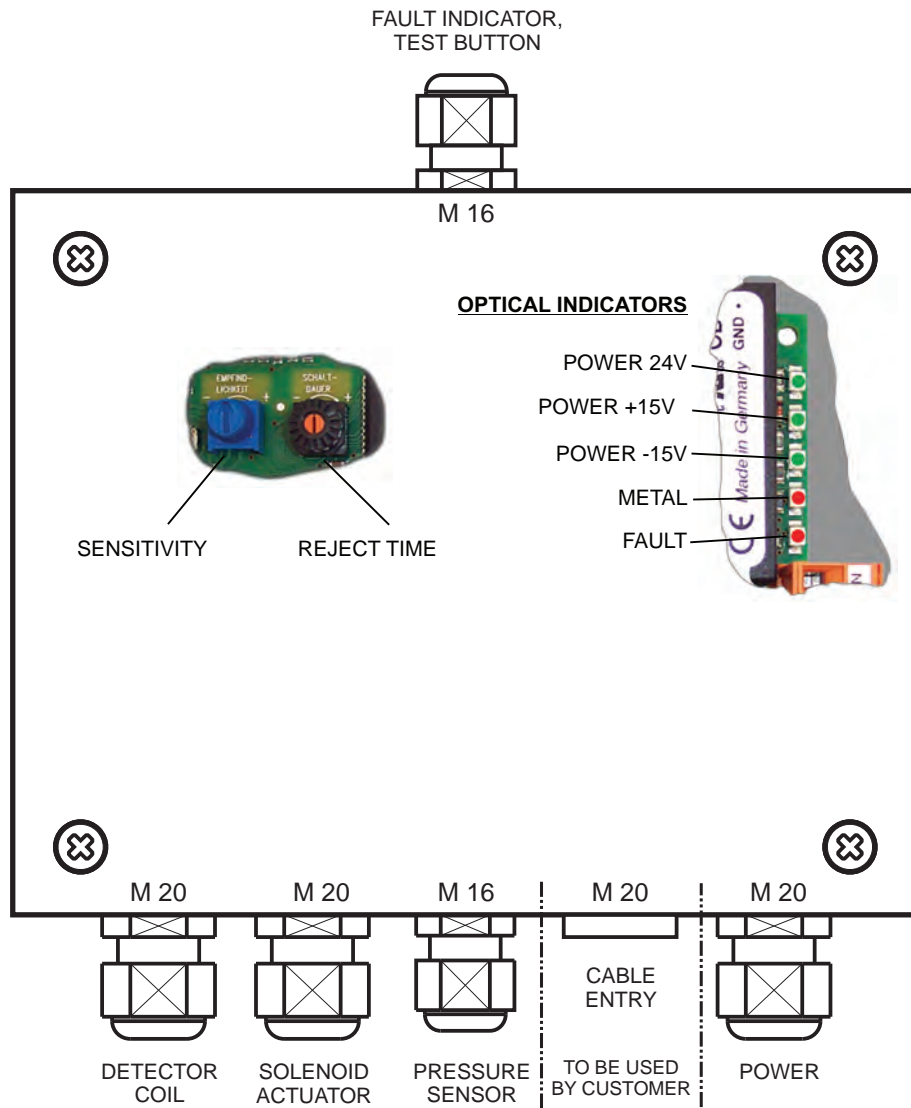

## TECHNICAL DATA

POWER SUPPLY:	100 – 240 V AC, 50/60 HZ
CURRENT CONSUMPTION:	MAX. 0,4 A
FUSE:	315 MA SLOW BLOW, 5x20 MM TO DIN
TYPE OF PROTECTION:	IP 54
WORKING TEMPERATURE RANGE:	- 5 °C TO +50 °C
STORAGE TEMPERATURE RANGE:	-10 °C TO +60 °C
REL. HUMIDITY:	UP TO 100 %
CONVEYING SPEED:	FREE FALL
REJECT DURATION:	0,14 TO 19 SECONDS, ADJUSTABLE
PAINTED:	RAL 3027 = RASPBERRY RED
AIR SUPPLY:	6 - 10 BAR (AIR PLUG 7,2)
AIR CONSUMPTION:	< 0,2 NORM-LITRES PER REJECT
BULK MATERIAL SIZE:	≤ Ø 10 MM
POWER CABLE:	APP. 1,6 M CABLE WITH PLUG (TWO POLE AND GROUND PIN) (US-VERSION WITH US-STANDARD PLUG)

OTHER VERSIONS AVAILABLE

## INPUTS AND OUTPUTS

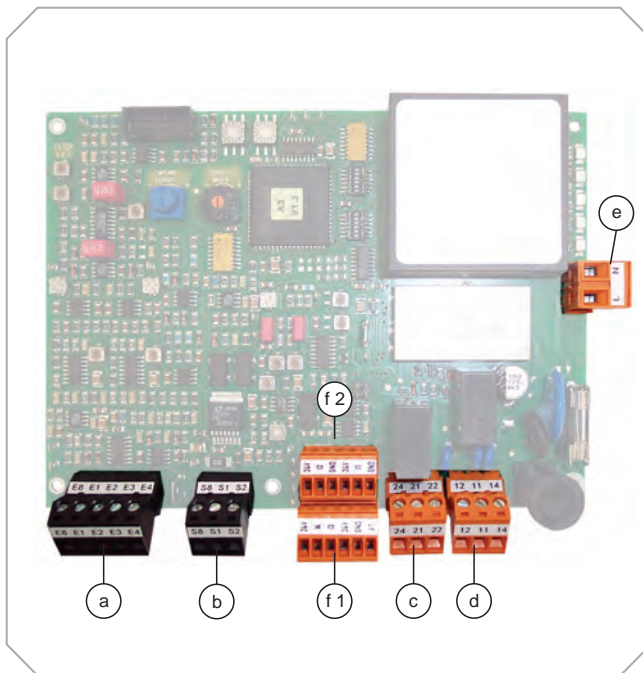

(f1) + (f2) FUNCTION BLOCK + (e) POWER +

(a) RECEIVER + (b) TRANSMITTER ARE USED BY MANUFACTURER.

### (f1) + (f2) FUNCTION BLOCK

#### CONNECTING EXAMPLES

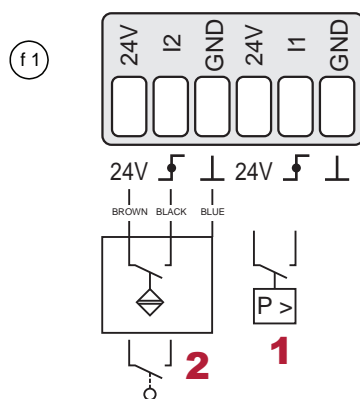

#### INPUTS (STANDARD LAYOUT)

- 1** I1 – PRESSURE MONITOR, CONTACTS CLOSED IF PRESSURE OK \*
- 2** I2 – INITIATOR (REJECT) FLAP POSITION SENSOR \*
- 3** I3 – RESET-BUTTON, EXTERNAL TO REST THE FAULT INDICATION (MAX. CABLE LENGTH 5M)
- 4** I4 – TEST-BUTTON, EXTERNAL TO TEST THE FUNCTION OF THE METAL SEPARATOR (MAX. CABLE LENGTH 5M)

\*ONLY IN CONJUNCTION WITH EXTENDED SELF MONITORING

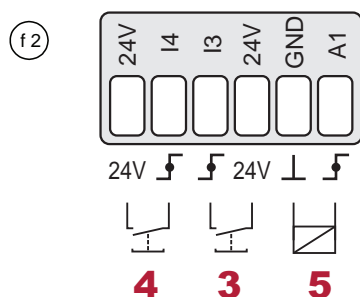

#### 24 VDC- OUTPUTS (STANDARD LAYOUT)

- 5** A1 – ACTIVE OUTPUT SWITCHES WHEN METAL IS DETECTED (OPERATES THE SOLENOID VALVE).

CONNECT ONLY POTENTIAL FREE CONTACTS (NO EXTERNAL SUPPLIED VOLTAGE)! MAX. (TOTAL) POWER CONSUMPTION ≤ 100 MA (FOR ALL CONNECTIONS / (f1) + (f2) )

## INPUTS AND OUTPUTS

### c RELAY 2 (FAULT)

- FLOATING RELAY CHANGE OVER CONTACT ACTUATED BY SELF MONITORING SYSTEM  
MAX. CONTACT LOAD: 250V/3A

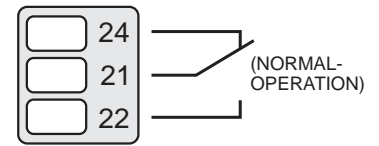

### d RELAY 1 (METAL)

- FLOATING RELAY-CHANGE OVER CONTACT ACTUATED WHEN METAL IS DETECTED  
MAX. CONTACT LOAD: 250 V / 3 A  
PULSE DURATION (AUTO-RESET): 0,14 SEC. TO 19 SEC. (ADJUSTABLE)

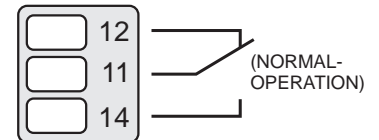

### e POWER SUPPLY

- 100 – 240 V AC, 50/60 Hz, CURRENT CONSUMPTION: MAX. 400 MA  
OTHER VERSIONS AVAILABLE



## Service and Calibration

Bunting service engineers are available at short notice to service and calibrate our full range of detectors in the UK and overseas. Bunting offers 3 levels of protection designed to provide specific services to optimise the performance and lifespan of metal detection equipment

### Pro-Start™

Pro-Start™ commissioning coverage ensures that a metal detector performs to company expectations from its first day on the job. A factory-trained service technician will be on-site to verify the installation, calibrate the metal detector to achieve top performance and train personnel. Pro-Start includes a calibration label for the detector, a complimentary set of test pieces (specify size and type on purchase) and a detailed calibration record for company files. It also extends the original one-year factory warranty to two years and includes two years of phone-based technical support.

### Pro-Maintenance™

Pro-Maintenance™ keeps the metal detector operating like new, which is critical, considering the impact of poor performance on customer satisfaction and other consequences. It provides either annual (Gold plan) or biannual (Platinum plan) visits by factory-trained service technicians to service and calibrate the metal detector and ensure the system is running the latest accurate software. The Pro-Maintenance plan also includes significant parts and labour discounts on any needed spares and repair work, on-site training for personnel during service & calibration visits and two years of phone based technical support.

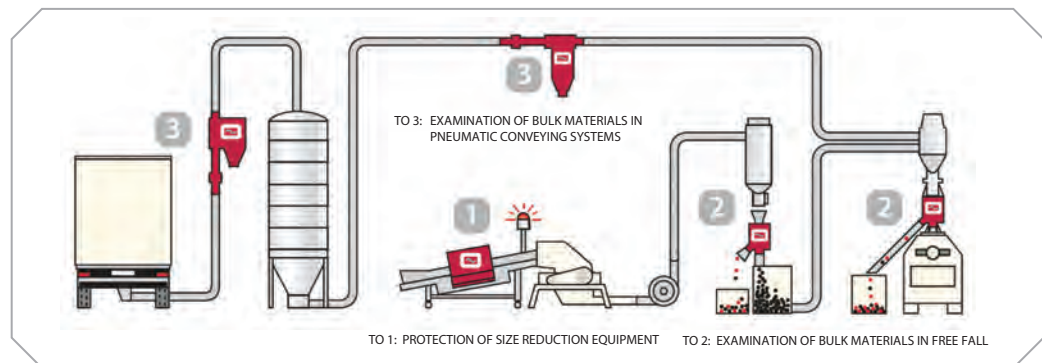

Burnt Meadow Road, Redditch, Worcestershire, UK, B98 9PA

Tel: +44(0)1527 65858

E-Mail: [sales.redditch@buntingmagnetics.com](mailto:sales.redditch@buntingmagnetics.com) • [www.mastermagnets.com](http://www.mastermagnets.com)