

In-Line Magnets



BULLET SEPARATOR

The Bullet Separator is designed for installation in vertical, or near vertical pipelines carrying grain or similar free flowing granular products. It is the ideal solution for extracting iron particles etc. from flour, grain, plastic granules and similar products being conveyed in ducted systems.

The bullet magnet system consists of a circular/conical core packed with everlasting, powerful strontium ferrite or 'rare earth' magnet material, protected by non-magnetic stainless-steel rings and fitted into a robust stainless-steel trunking. As material flows over the magnetic bullet, any ferrous particles are attracted to the highly magnetic surface and securely held in position. Guide strips on the housing deflect material directly on to the bullet surface. Flanges are provided at inlet and outlet for connection into pipe work.

Quick and Easy Cleaning

The bullet separator has been specifically designed to reduce downtime. The bullet is mounted to the trunking door, which can be opened using quick-action catches allowing it to be wiped clean in seconds, causing only minimal disruption to production.



Specifications:

- **General material:** 304 stainless steel housing
- **Magnet material:** High-density Ceramic (CR) permanent magnetic material.
Rare Earth (NE) models available.
- **Magnet design:** Built around a central plated steel cone and interposed with high permeability plated steel poles, sized to produce the optimum magnetic field.
- **Construction:** Fully welded 304 stainless steel housing with flanged inlet and outlet connections to suit client pipework. The Bullet Magnet is door mounted and pivoted for easy cleaning.
- **Method of cleaning:** Manual, from outside of housing, utilising hinged swing-away magnet.
- **Sizes:** Available in 100mm through 500mm line sizes. Special sizes available upon request.

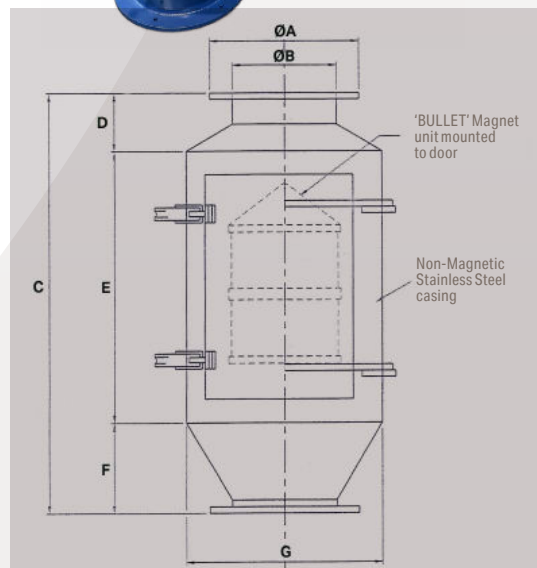

TYPE	A mm	B mm	C mm	D mm	E mm	F mm	G mm	HANDLES	WEIGHT Kg
MM 100	160	100	570	70	370	130	225	1	30
MM 125	185	125	680	100	400	180	230	1	40
MM 150	210	150	680	100	430	150	270	1	50
MM 200	286	200	790	100	520	170	375	2	90
MM 250	336	250	950	100	580	270	425	2	145
MM 300	386	300	1000	100	600	300	475	2	210
MM 400	486	400	1100	100	700	300	620	2	350
MM 500	586	500	1200	100	780	320	780	2	490

PNEUMATIC IN-LINE MAGNETS (PIM)

Design features full-flow architecture that leaves the product stream unobstructed. Tapered transitions guide material directly over the face of the hinged plate magnet, which swings away from the housing for quick external cleaning.

- Designed for unobstructed product flow.
- Compression couplings speed in-line installation.
- For dilute phase conveying up to 15 psi.
- Best suited for horizontal installation, portable cart available.
- Powerful magnetic field covers entire cross-section of product flow.
- High-energy rare earth tapered step plate magnets are standard.
- Magnet swings out for easy cleaning.
- All finishes available, including food and sanitary.



See Fig. 1

Model No.	A* mm	B mm	C mm	D mm	E mm	F mm	G mm
PIM-2-CR	50	863	100	25	150	92	140
PIM-2-NE	50	812	100	25	150	85	140
PIM-3-CR	75	914	100	75	150	146	140
PIM-3-NE	75	812	100	75	150	111	140
PIM-4-CR	100	914	150	87	200	171	140
PIM-4-NE	100	812	150	87	200	146	140
PIM-5-CR	125	104	200	100	250	257	140
PIM-5-NE	125	965	200	100	250	171	140
PIM-6-CR	150	1397	300	100	350	282	177
PIM-6-NE	150	1320	300	100	350	196	177
PIM-8-CR	200	1549	350	125	400	374	177
PIM-8-NE	200	1346	350	125	400	266	177
PIM-10-CR	250	1651	400	165	457	425	177
PIM-10-NE	250	1447	400	165	457	316	177

Specifications:

- **General material:** 302/ 304 stainless steel with standard size tube ends.
- **Magnet material:** High-density Ferrite (CR) permanent magnetic material. Rare Earth (NE) models available.
- **Magnet design:** Standard plate magnet with 400 series stainless steel exposed pole face. Other face styles available.
- **Construction:** Housing is seam welded into an integral unit. Magnet furnished with hinge, latches and silicone gasket. Compression couplings for installation and special adapters are available upon request.
- **Method of cleaning:** Manual, from outside of housing, utilising hinged swing-away magnet. Self-cleaning models available (SC).
- **Sizes:** Available in 50mm through 250mm line sizes. Special sizes available upon request.



Fig. 1

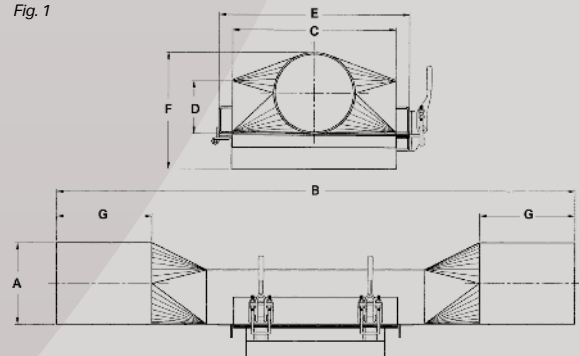

GRAVITY IN-LINE MAGNETS (GIM)

Allows the use of our powerful Plate Magnets in round, sloping spouting where material is under gravity flow. For effective tramp capture, spouting should be angled no more than 60° from horizontal.

- Tapered step magnet
- All finishes available including: food and sanitary
- Ceramic and High-Intensity (NHI) Rare Earth are available



See Fig. 1

Model No.	A* mm	B mm	C mm	D mm	E mm	F mm	G mm
GIM-5	125	863	200	100	250	196	140
GIM-5-NE	125	736	200	100	250	163	140
GIM-6	150	965	300	109	355	196	140
GIM-6-NE	150	863	300	109	355	163	140
GIM-8	200	1014	350	125	406	196	140
GIM-8-NE	200	965	350	125	406	163	140
GIM-10	250	1219	400	165	457	196	140
GIM-10-NE	250	1016	400	165	457	163	140
GIM-12	300	1295	550	165	609	196	140
GIM-12-NE	300	1092	550	165	609	163	140

Specifications:

- **General material:** 302/304 stainless steel with standard size tube ends.
- **Magnet material:** High-density Ferrite (CR) permanent magnetic material. Rare Earth (NE) models available.
- **Magnet design:** Standard plate magnet with 400 series stainless steel exposed pole face. Other face styles available.
- **Construction:** Housing is seam welded into an integral unit. Magnet furnished with hinge, latches, and silicone gasket. Compression couplings for installation and special adapters are available upon request.
- **Method of cleaning:** Manual, from outside of housing, utilising hinged swing-away magnet. Self cleaning models available (SC).
- **Sizes:** Available in 12.5cm through 30cm line sizes. Special sizes available upon request.

MAGNETIC SEPARATION AUDITS

Bunting is able to offer free audits on magnetic separation equipment.

The audit includes:

- Checking each magnet for magnetic strength
- Checking the structural integrity of magnets
- A location review
- Checking the effectiveness of the cleaning regime

Fully trained and experienced Bunting engineers will conduct each audit. These engineers will have in depth knowledge of the relevant industries and applications as well as the installation and manufacturing processes.

Contact us today to book a completely free audit of your magnetic separation equipment.



Bunting has over sixty years experience providing innovative magnetic solutions to industries involved in recycling, demolition and reclamation, mining and quarrying, food processing, ceramics production and powders and minerals processing. The Bunting range of systems are known for their high performance and reliable operations.

Please visit our website at www.bunting-redditch.com to view our full range of Equipment where brochure and video downloads are available.

For more information on our full range of products please contact us on the contact details below.

BUNTING - REDDITCH
BURNT MEADOW ROAD, NORTH MOONS MOAT,
REDDITCH, WORCESTERSHIRE, B98 9PA
E-MAIL: SALES.REDDITCH@BUNTINGMAGNETICS.COM
TEL: +44 (0)1527 65858

www.BUNTING-REDDITCH.COM