

Overband Magnets

Bunting have been manufacturing permanent magnetic and electromagnetic equipment for over 60 years. Recent investment in manufacturing techniques and magnet technology have enabled us to offer the most comprehensive range of overband magnets with the highest levels of performance.

Supplying all industries, volume OEM's and one off installations, Bunting has the overband magnet to suit your application.

- Three distinct model types of permanent overband magnets
- Three deep field model types of electro overband magnets
- Compact and lightweight permanent and electro overband magnets
- Range of overband magnets available now from stock



With sales offices and distributors throughout Europe, Bunting offers:

- An extensive range of design sizes to suit all applications
- Solutions for both cross belt and inline installations
- Welding to ISO3834 accredited standards
- Accreditation to ISO9001 quality standards
- Technical application engineers available to advise and assist
- Custom design service
- Same day dispatch on a vast range of spare parts
- Qualified service engineers and technical support

Videos

- Bunting electro overband magnets & eddy current separator
- Bunting permanent overband magnets
- Bunting electro-magnetic overbands

Permanent Overband Magnets



PCB Permanent Overband

Heavy duty range designed mainly for recycling and quarrying industries to remove ferrous tramp. For conveyors 300 to 2000mm wide at operating heights up to 400mm.

- High magnetic performance
- Selection available from stock
- Range of sizes and options to suit your application



PCB-C Compact Permanent Overband

Aimed at the volume mobile equipment market. More compact and lightweight. For conveyors 600 to 1500mm wide at operating heights up to 300mm.

- Latest manufacturing technology to reduce weight and size
- Increased magnetic force to weight ratio.



QBC Quick Belt Change

Fast belt change overband magnet for reduced downtime. For conveyors 600 to 1500mm wide at operating heights up to 300mm.

- Top and bottom belt guides and guards
- Range of sizes and options to suit your application

Electro-Overband Magnets



ElectroMax Compact Air Cooled

High performance, lightweight, air cooled electromagnetic overband. For conveyors 1000 to 1800mm wide at operating heights up to 600mm.

- Highest magnetic power to weight ratio of any overband magnet
- No oil present
- Low profile, compact design
- Designed using the latest finite element analysis software



OCW Heavy Duty Oil Cooled

Heavy duty oil cooled electromagnetic overband range available in over 300 sizes. For conveyors 500 to 3000mm wide at operating heights up to 1000mm.

- Manganese baseplate for high wear and impact resistance
- Unique long life powerful magnetic coil design
- ATEX rated models available



ACW Heavy Duty Air Cooled

Heavy duty air cooled electromagnetic overband range available in over 300 sizes. For conveyors 500 to 3000mm wide at operating heights up to 1000mm.

- No oil present
- Permanent extension magnets can be attached to extend the discharge zone away from the extraction point

Model Guide and Options

All our overbands have a vast range of options to suit your application and requirements.

Please call our experienced applications engineers to help specify the correct magnet and options for your individual application.

MODEL	PCB	PCB-C	QBC	EMAX	OCW	ACW
Permanent magnet	•	•	•			
Electro-magnet				•	•	•
Maximum operating gap	400	300	300	600	1,000	1,000
Maximum customer belt width	2000	1500	1500	1800	3000	3000
Light weight		•		•		
Electric drive of belt	•	•	•	•	•	•
Electromagnet cooling medium				Air	Oil	Air
Cantilever frame design			•			
OPTIONAL FEATURES						
Hydraulic drive of belt	•	•	•			
ATEX 22	•				•	
Heat resistant, antistatic belt	•	•	•	•	•	•
Armoured belt	•			•	•	•
Stainless steel frame	•	•	•	•	•	•
Custom design mounting brackets	•		•	•	•	•
Full sheet guarding	•			•	•	•
Belt tracking limit switches	•	•		•	•	•
Rotation sensor	•	•	•	•	•	•
Permanent magnetic extension	•				•	•
1 pole across bottom face of magnet	•	•	•			
2 poles across the bottom of magnet	•					
3 poles across the bottom of magnet	•	•	•			
Special paint coatings	•	•	•	•	•	•

Installation Options

Whilst the most common mounting position for an overband magnet is crossbelt, inline models are also available which maximise magnet efficiency due to the material already being airborne.

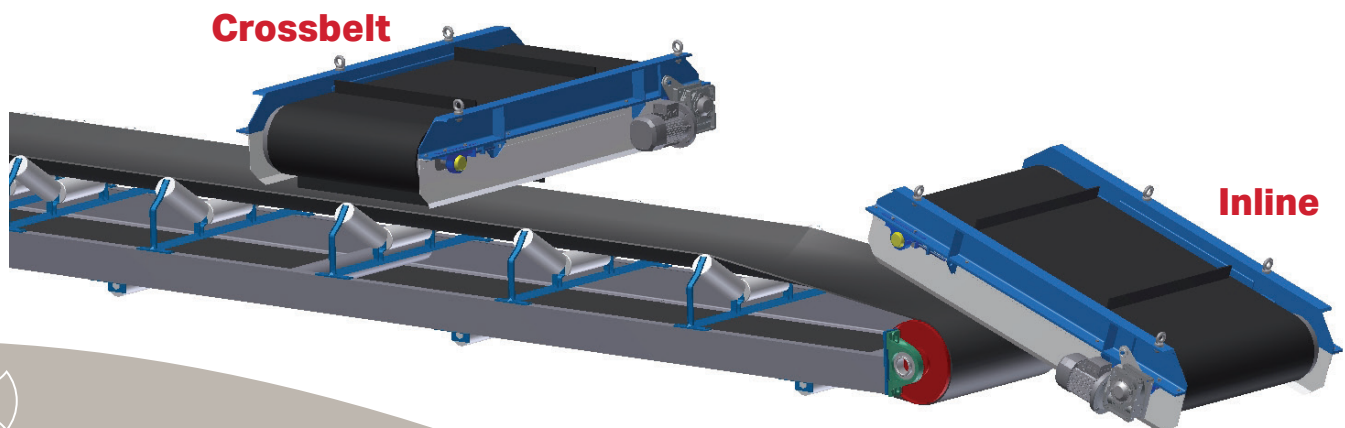

Crossbelt

Inline

Industries and Applications

- Mobile crushers, screens and shredders
- MRF (Material Recovery Facility) plants
- Separation of ferrous contamination in quarries
- Removal of ferrous in mining operations
- Wood waste processing applications
- Separation of ferrous in fragmentiser metal recovery
- Removal of ferrous from foundry applications
- Separation of ferrous metals from municipal solid waste
- Removal of ferrous contamination in glass cullet recycling
- Separation of ferrous from kerbside collection recycling
- Separation of ferrous in skip waste recycling

Site Evaluation Service

Bunting offer a site evaluation service to give us more understanding of complex or specialised applications, this enables us to evaluate a client's application so that we can recommend the most effective form of magnetic separation.

Bunting has over sixty years experience providing innovative magnetic solutions to industries involved in recycling, demolition and reclamation, mining and quarrying, food processing, ceramics production and powders and minerals processing. The Bunting range of systems are known for their high performance and reliable operations.

Please visit our Website at www.bunting-redditch.com to view our full range of Equipment where brochure and video downloads are available.

For more information on our full range of products please contact us on the contact details below.

BUNTING - REDDITCH

**BURNT MEADOW ROAD, NORTH MOONS MOAT,
REDDITCH, WORCESTERSHIRE, B98 9PA**

E-MAIL: SALES.REDDITCH@BUNTINGMAGNETICS.COM

TEL: +44 (0)1527 65858

BUNTING-REDDITCH.COM