

easySCOPE



FOREIGN BODY DETECTOR FOR PACKAGED GOODS  
**TECHNICAL DATASHEET**

Version 05/19

# DIMENSIONS easySCOPE 400

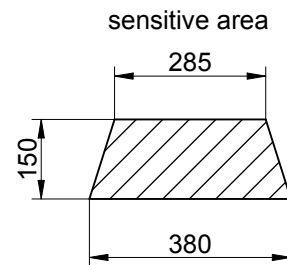
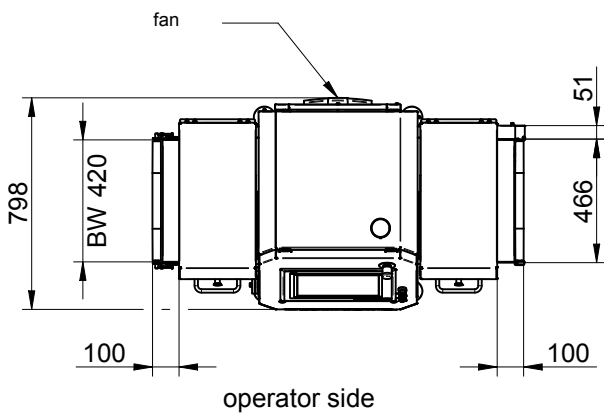
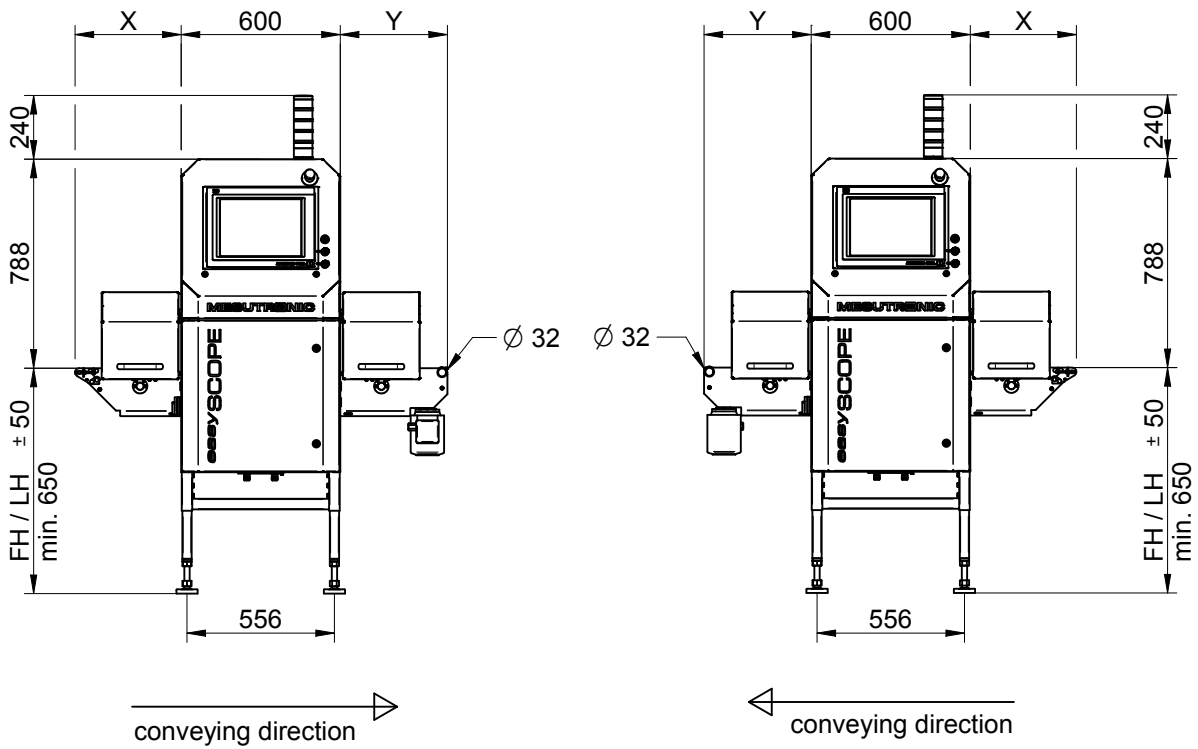

Product height	Product width
0	380
30	360
60	340
90	325
120	305
150	285

Conveyor length					
X	400 *	600	800	1000	1200
Y	400 *	600	800 *	1000	1200

standard length

Line heights LH									
Adjustable foot	650	700	750	800	850	900	950	1000	1050
Castor wheels	-	-	-	800	850	900	950	1000	1050

# DIMENSIONS easySCOPE 600

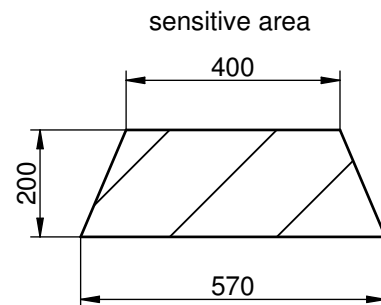
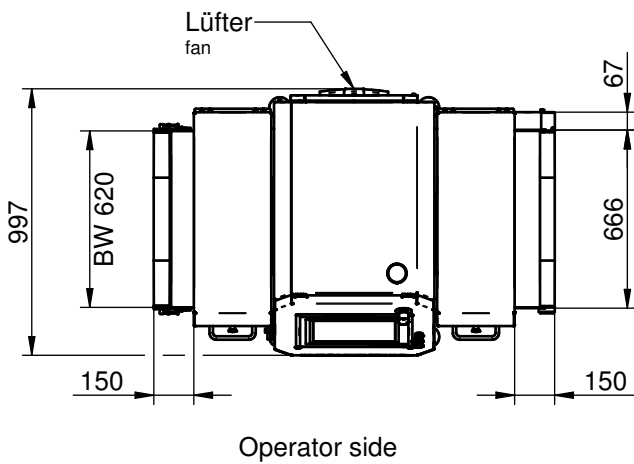
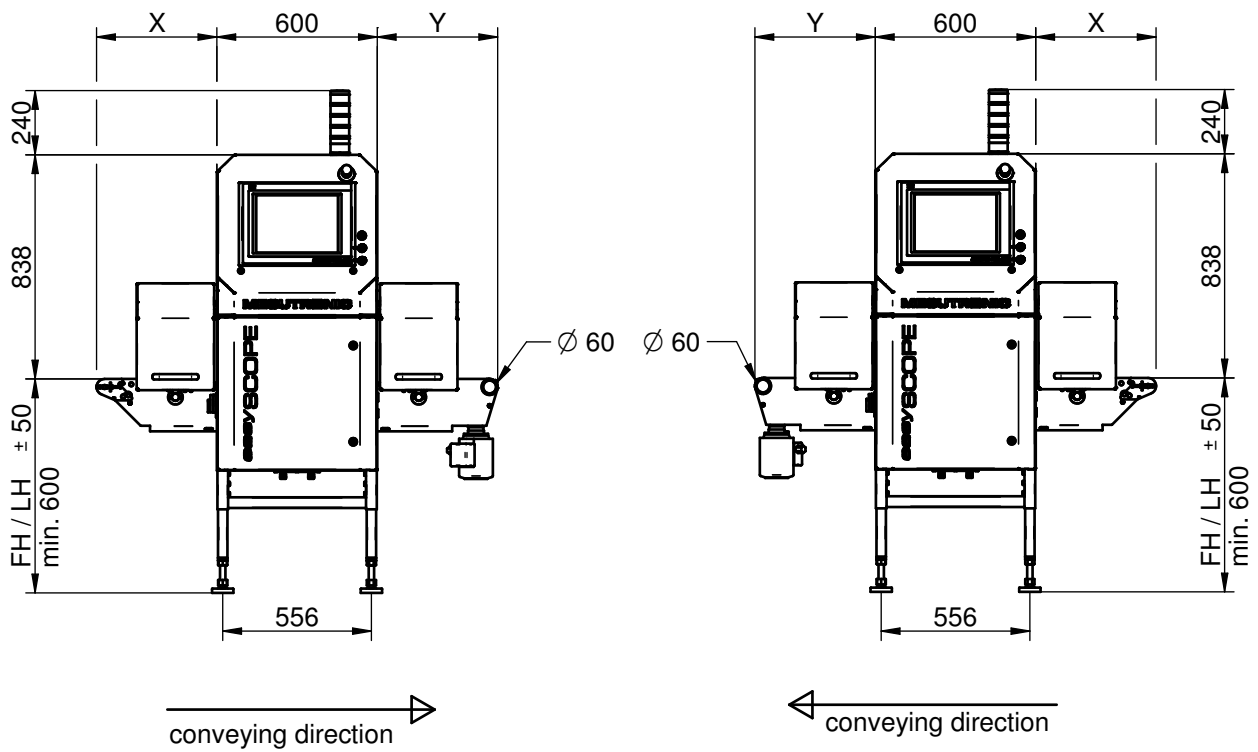

Product height	Product width
0	570
30	545
60	520
90	495
120	470
150	445
180	415
200	400

Conveyor length					
X	450 *	650	850	1050	1250
Y	450 *	650	850 *	1050	1250

standard length

Line heights LH									
Adjustable foot	600	650	700	750	800	850	900	950	1000
Castor wheels	-	-	-	750	800	850	900	950	1000

## TECHNICAL DATA

Model	easySCOPE 400	eaysSCOPE 600
HOUSING:	STAINLESS STEEL 304, SANDBLASTED	
PROTECTION CLASS:	HOUSING IP 54; CONVEYOR IP 65	
AMBIENT TEMPERATURE:	+ 5 °C TO + 28 °C WITH FILTER FAN + 5 °C bis + 40 °C WITH AIR COOLING	
STORAGE TEMPERATURE:	- 10°C TO + 60°C	
RELATIVE HUMIDITY:	UP TO 90% (without condensation water)	
OPERATING VOLTAGE:	230 V ± 10% AC, 50-60 Hz	
MAINS PROTECTION:	10 A	
POWER CONSUMPTION:	670 W WITH FILTER FAN 840 W WITH AIR COOLING	
MAINS CONNECTION:	APPROX. 3 m CABLE WITH SAFETY PLUG	
X-RAY GENERATOR:	80 kV / 5 mA, MAX. 210 W	
X-RAY DETECTOR:	410 mm, EFFECTIVE DIODE SIZE 0,8 mm	614 mm, EFFECTIVE DIODE SIZE 0,8 mm
X-RAY EMISSION:	< 0,5 µSv/h	
RADIATION PROTECTION CURTAIN:	LEAD-FREE RUBBER MATRIX WITH BACKING FABRIC, BLACK APPROVED FOR FOOD ACCORDING TO FDA	
CONVEYING SPEED: <sup>1</sup>	0,1 m/s TO 1,2 m/s	
BELT WIDTH:	420 mm	620 mm
BELT MATERIAL:	POLYURETHANE, WHITE APPROVED FOR FOOD ACCORDING TO FDA, USDA, EU	
LOAD:	MAX. 5 kg AT v = 1,2 m/s MAX. 10 kg AT v = 0,6 m/s	MAX. 10 kg AT v = 1,2 m/s MAX. 20 kg AT v = 0,6 m/s
WEIGHT:	300 kg	500 kg

## STANDARD SCOPE OF DELIVERY

- USER MANUAL
- EC CONFORMITY DECLARATION
- FOREIGN BODY DETECTOR WITH INTEGRATED BELT CONVEYOR
- INDUSTRIAL PC WITH 15,4" FLAT MONITOR AND TOUCH SCREEN
- UNINTERRUPTIBLE POWER SUPPLY
- FILTER FAN
- 4 COLOR LED SIGNAL TOWER
- HIGH PERFORMANCE IMAGING SOFTWARE
- QUICK-RELEASE-SYSTEM FOR BELT CLEANING
- FOREIGN BODY DETECTOR WITH INTEGRATED BELT CONVEYOR SYSTEM

## DELIVERABLE OPTIONS

- WATER JET-PROTECTIVE COVERS FOR FILTER FAN AND AMBIENT TEMPERATURE UP TO 28°C (IP 55)
- AIR COOLING SYSTEM FOR AMBIENT TEMPERATURE UP TO 40°C (IP 34)
- AIR COOLING SYSTEM FOR AMBIENT TEMPERATURE UP TO 40°C AND CLEANING-INTENSIVE ENVIRONMENTS (IP65)
- ACOUSTICAL SIGNALLING DEVICE
- REJECT SYSTEMS: PUSHER, AIR JET, ONLY EASYSOPE 600: FLAP
- SIDE GUIDES
- LOCKABLE CONTAINER FOR REJECTED PRODUCT
- SAFETY COVER: STAINLESS STEEL OR MAKROLON
- HIGH-RESOLUTION X-RAY DETECTOR (EFFECTIVE DIODE SIZE 0,4 mm)
- CASTOR WHEELS
- WEAR-PROTECTED RADIATION PROTECTION CURTAIN